

HALGAN GENERAL PURPOSE PIT S SERIES 1000 LITRES DETAIL

Notes

1. Product

Halgan General Purpose Pit are manufactured from chemical grade polyethylene.

The Halgan General Purpose Pit can be installed above and below ground. The Trap is designed to slow the influent and allow contaminated water full or silt, oil and other contaminants to settle before discharging to the sewer or stormwater system.

2. Application

The Halgan General Purpose Pit is used for treatment of waste water from commercial premises. For example manufacturing, car wash bay, kennels, washdown areas and stormwater. Refer to the local Trade Waste Standards. This standard outlines all the discharge parameter limits that can be accepted into the sewage system.

3. General

3.1 Tank constructed from Polyethylene.

3.2 The Halgan General Purpose Pit is to be installed in a location that will not cause a nuisance, obstruct fire access, cannot be vandalised or be damaged by vehicles.

3.3 The Halgan General Purpose Pit must have ease of access to pumpout point for maintenance.

3.4 A hose tap fitted with RPZD backflow protection (as per AS/NZS 3500) must be installed within 5 metres of the grease trap for maintenance and cleaning.

3.5 Non standard installations require Halgan approval.

4. Installation above ground

4.1 The Halgan General Purpose Pit is to be supported on a 100mm thick concrete pad.

4.2 A stand is available for S Series models if required.

4.3 Any maintenance platform must be installed in accordance with Australian Standard 1657-1992 allowing safe access while inspecting and maintaining the Halgan General Purpose Pit.

4.4 All pipes connecting to the Halgan General Purpose Pit shall be fully supported; there shall be no stress on the tank connections.

4.5 All stormwater must be diverted away from the Halgan General Purpose Pit to prevent undermining of foundation.

5. Installation below ground

5.1 All connections to the Halgan General Purpose Pit shall be in accordance with the appropriate authorities.

5.2 Any excavation exceeding 1.5 metres in depth shall comply with the construction safety acts and regulations before backfilling.

5.3 The Halgan General Purpose Pit must be filled with water prior to backfilling.

6. Excavation dimensions

6.1 The excavated hole width shall be kept as narrow as practicable. The depth shall not be greater than 150mm more than the required depth.

6.2 75mm clearance is required at the sides of tank.

7. Over excavation

7.1 Where an excavation has been made deeper than required, the excess depth shall be filled either with 4:1 sand cement compacted to achieve 98% compaction or concrete.

8. Water Charged Ground

8.1 Installation in areas subject to flooding & groundwater is only permitted when the level of water does not exceed the height of the middle of the tank.

8.2 In areas of heavy, clay-like soils, the installation is only permitted when there is sufficient drainage underneath the body of the tank.

9. Bedding/Backfill

9.1 The bedding/backfill material shall be Blue Metal granular material up to 10mm diameter.

9.2 The bedding/backfill shall be minimum 75mm thick.

9.3 The bedding/backfill shall be thoroughly compacted by tampering at 300 mm layers.

9.4 The bedding/backfill material shall encase the whole tank.

9.5 Foreign material such as builder's waste, bricks, and concrete shall not be used as backfill.

9.6 The backfill shall be compacted to restore the excavated hole as near as practicable to the normal ground.

300mm & 600mm RISER SIZES AVAILABLE
(RISER HEIGHTS GREATER THAN 900mm
REQUIRE HALGAN APPROVAL)

INSTALLATIONS WITH B CLASS LIDS ADD 50mm TO FSL
INSTALLATIONS WITH D CLASS LIDS ADD 100mm TO FSL

VENT PIPE TO DISCHARGE TO
ATMOSPHERE IN ACCORDANCE WITH
AS/NZS 3500

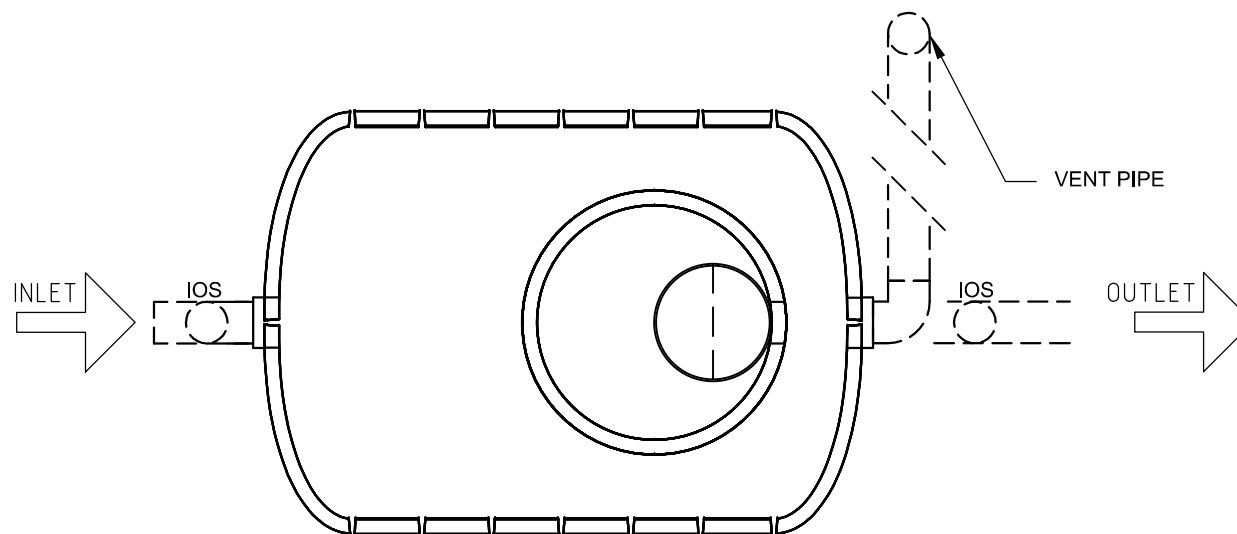
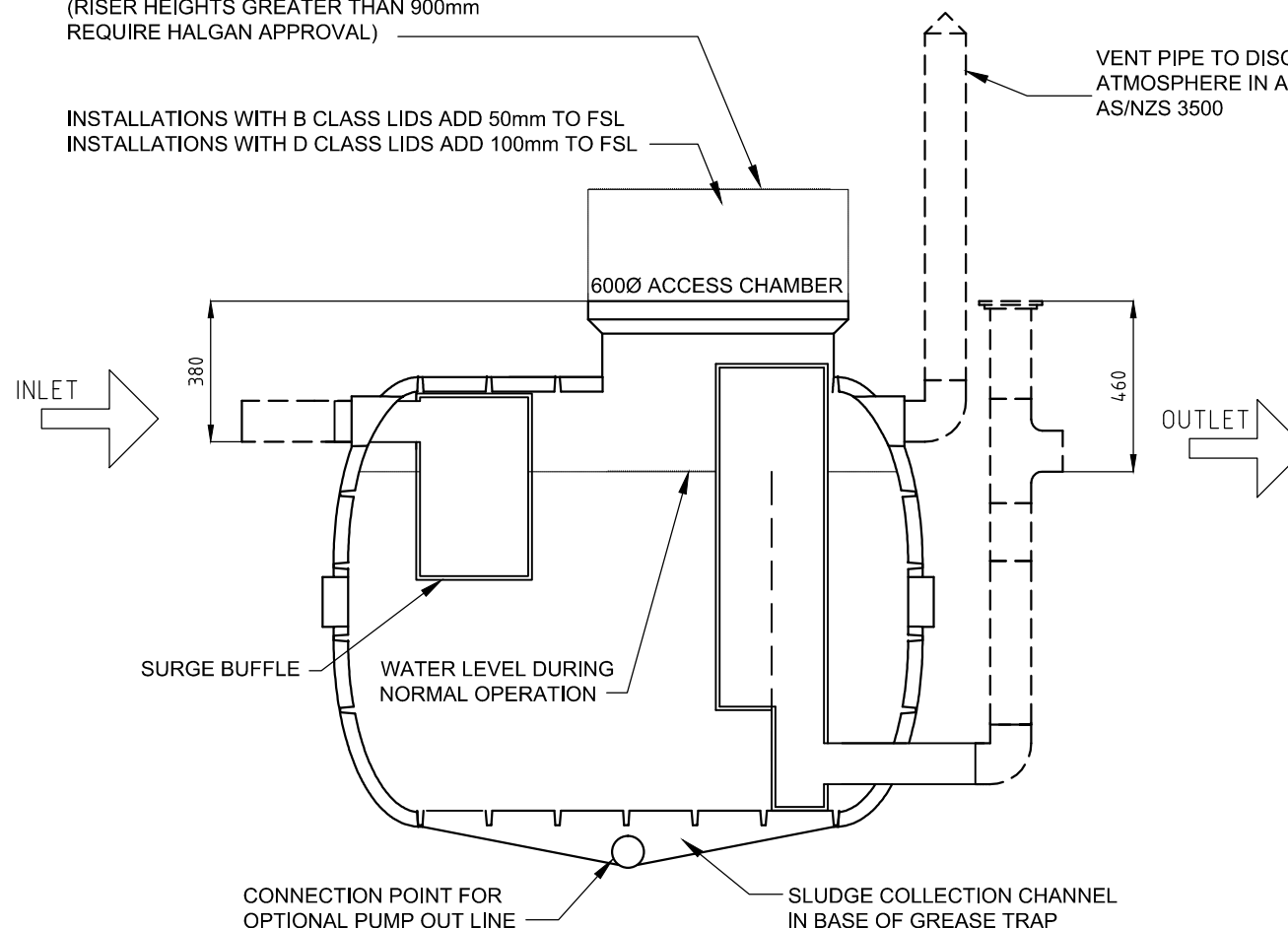

HALGAN HGPPS1000 DIMENSIONS							
DIMENSIONS DO NOT INCLUDE PIPEWORK OR ACCESS LIDS							
MODEL	HEIGHT	WIDTH	LENGTH	VOLUME	WEIGHT	A (INLET)	B (OUTLET)
HGPPS1000	1550mm	1130mm	1700mm	1000 L	95 KG	380mm	460mm



REV	DATE	DESCRIPTION	BY	CHKD	APP
A-2	10.06.2015	NOTES, DIMENSION TABLE & DETAIL AMENDED	LB	JB	KH
A-1	23.05.2013	NOTES, DIMENSION TABLE & DETAIL AMENDED	DN	SM	KH
A	15.10.2012	DETAIL DESIGN	DN	SM	KH

THIS DRAWING AND THE INFORMATION CONTAINED HEREON ARE THE PROPERTY OF HALGAN PTY LTD AND MUST NOT BE COPIED, REPRODUCED OR USED WITHOUT THE WRITTEN PERMISSION OF HALGAN PTY LTD.

DO NOT SCALE IF IN DOUBT ASK



Freecall 1800 626 753
22, Ethel Avenue
Brookvale NSW 2100
admin@halgan.com.au
www.halgan.com.au



HALGAN HGPPS1000
LITRES DETAIL

DRAWN	DATE	SCALE	REV.
LB	12.02.2016	1:20	A-2
CHKD			
JB			
DWG NO.	HGPPS1000		