

HALGAN OIL / WATER SEPARATOR DETAIL

Notes

1. Application

The Halgan Oil/Water Separator is ideal in a range of applications including: Mechanical work shops - Truck & Car wash bays—Fuel depots - Panel beaters - Service Stations - Marinas - Airports.

2. Quality Controls

The Halgan Oil/Water Separator is manufactured using the most modern and technically advanced moulding equipment in the world - the computer controlled equipment guarantees perfect quality control throughout the manufacturing process.

3. Warranty:

Electrical components are covered by a 12 months warranty. All products are covered by a 7 year manufacturers warranty. Halgan Pty Ltd guarantees all products are free from defects.

4. Pumps

All pumps used are Sydney Water approved Diaphragm pumps. The pump is selfpriming, non-emulsifying. The pump housing is manufactured from corrosion resistant aluminium. The diaphragm is a high grade Nitrile with Nitrile valves and stainless steel seats.

5. Maintenance

Under normal operating conditions the oil/water separator requires servicing every 3 months. The service can be completed by our EPA licensed vehicles and qualified staff. The manual oil skimmer will drain any buildup of oil and deposit it into the appropriate container. The recycled oil has to be disposed at an EPA licensed depot.

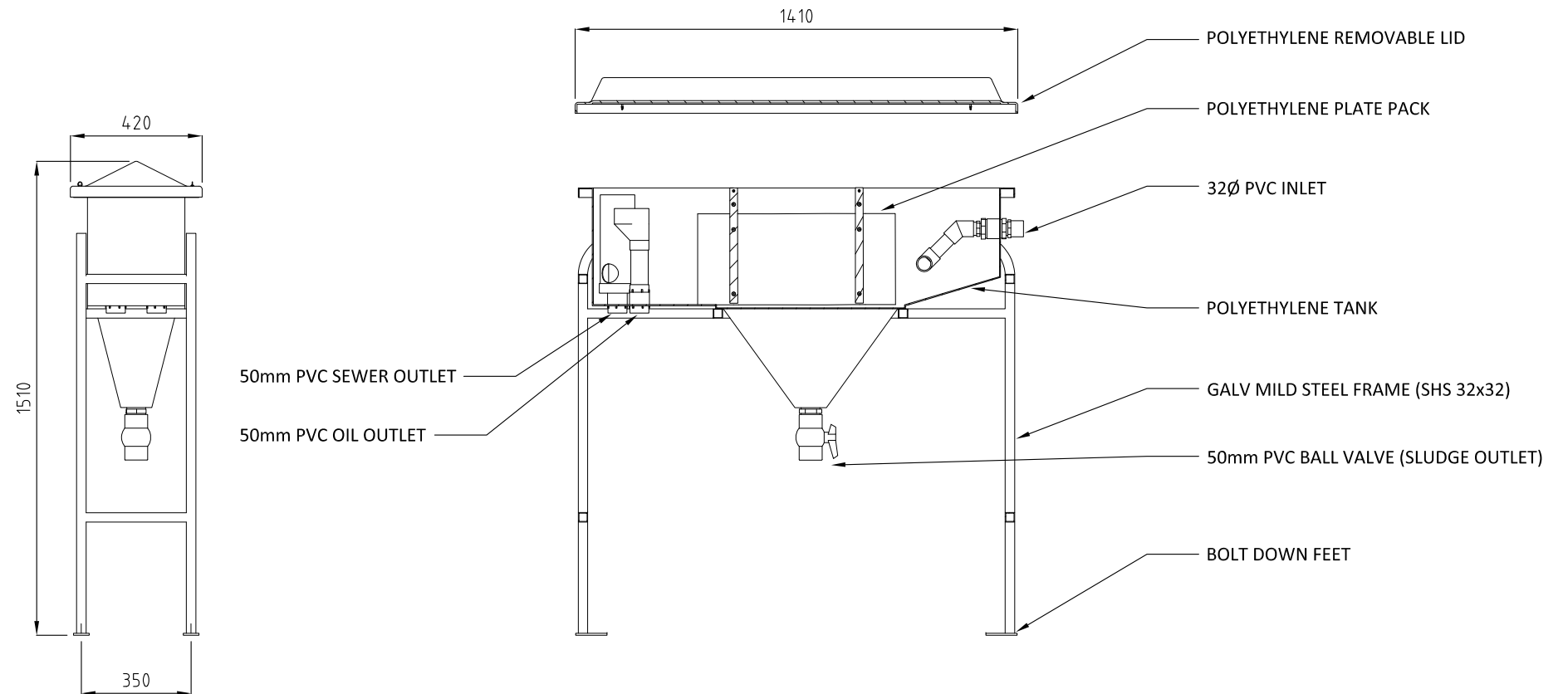

HALGAN HCP1 DIMENSIONS

MODEL	HEIGHT	WIDTH	LENGTH	VOLUME	WEIGHT
HCP1 1000	1510mm	420mm	1410mm	1000 L	45KG
HCP1 1500	1510mm	700mm	1500mm	1500 L	60KG
HCP1 2000	1450mm	1100mm	1100mm	2000 L	80KG

THIS DRAWING AND THE INFORMATION CONTAINED HEREON ARE THE PROPERTY OF HALGAN PTY LTD AND MUST NOT BE COPIED, REPRODUCED OR USED WITHOUT THE WRITTEN PERMISSION OF HALGAN PTY LTD.						DRAWN DN		DATE 04.11.2012		
DO NOT SCALE IF IN DOUBT ASK						CHECKED SM		SCALE 1:20		REV. A3
REV	DATE	DESCRIPTION	BY	CHKD	APP	DWC NO. HCP1		REV. A		
HALGAN OIL / WATER SEPARATOR DETAIL						X X X X X				