

## PRODUCT FEATURES

- Fully automatic self cleaning cycle. Actively removes collected grease & oils from tank without any operator assistance. Comes complete with precision timer interface and Grease Collector.
- Constructed of corrosion resistant materials suitable for installation in virtually any location.
- Integrated Motor/Grease Outlet/Heater/Lid enables a fast, do-it-yourself unit operation reversal.
- Compact footprint.
- Two (2) No-Hub Connectors provided.

## SPECIFICATIONS

Construction: \_\_\_\_\_ Rotationally Molding Polyethylene  
 Electrical: \_\_\_\_\_ 115 VAC, 50/60 Hz, 1173 Watts (10.2 Amps)\*  
 Electrical Cord Length: \_\_\_\_\_ 8 ft  
 Flow Rating: \_\_\_\_\_ 25 GPM (2.21 l/s)  
 No. of Skimming Wheels: \_\_\_\_\_ 1  
 Skimming Rate: \_\_\_\_\_ 9 lbs (4.08 kg) Per Hour  
 Grease Retention Capacity: \_\_\_\_\_ 56.4 lbs (25.6 kg)  
 Internal Solids Strainer Capacity: \_\_\_\_\_ 1.85 gal (7 L)  
 Inlet/Outlet: \_\_\_\_\_ 2 in (50 mm)  
 Product Weight: \_\_\_\_\_ 48 lbs (21.7 kg)

\*For Additional Electrical Configurations, see Electrical Variations section on page 2.

### END VIEW

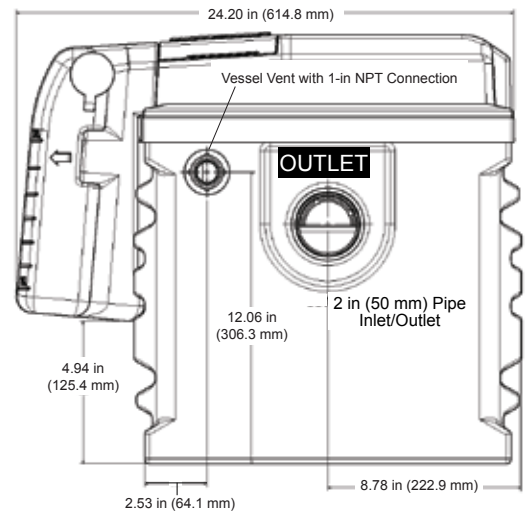

### SIDE VIEW

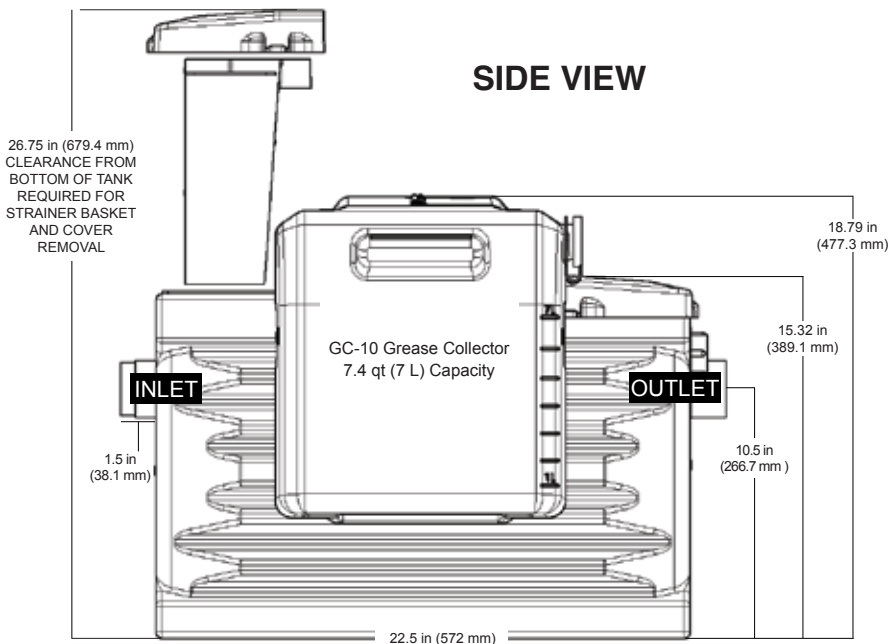

### TOP VIEW

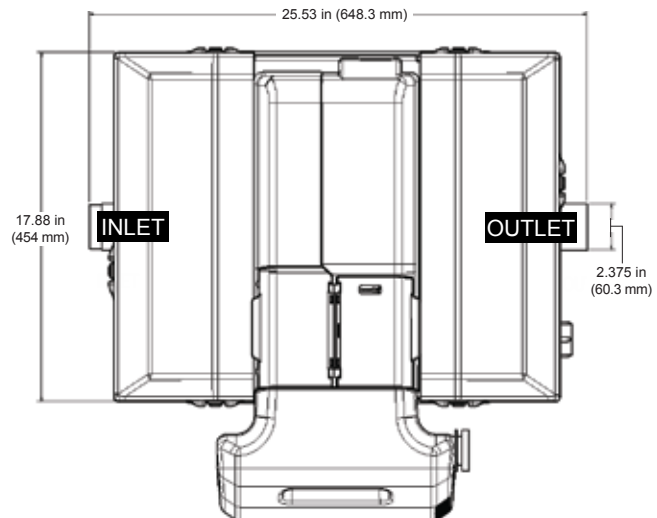

Conforms to ASME Standard  
ASME A112.14.3 and A112.14.4



Complies with C22.2



Conforms to Performance  
Requirements of  
EN1825 Standard

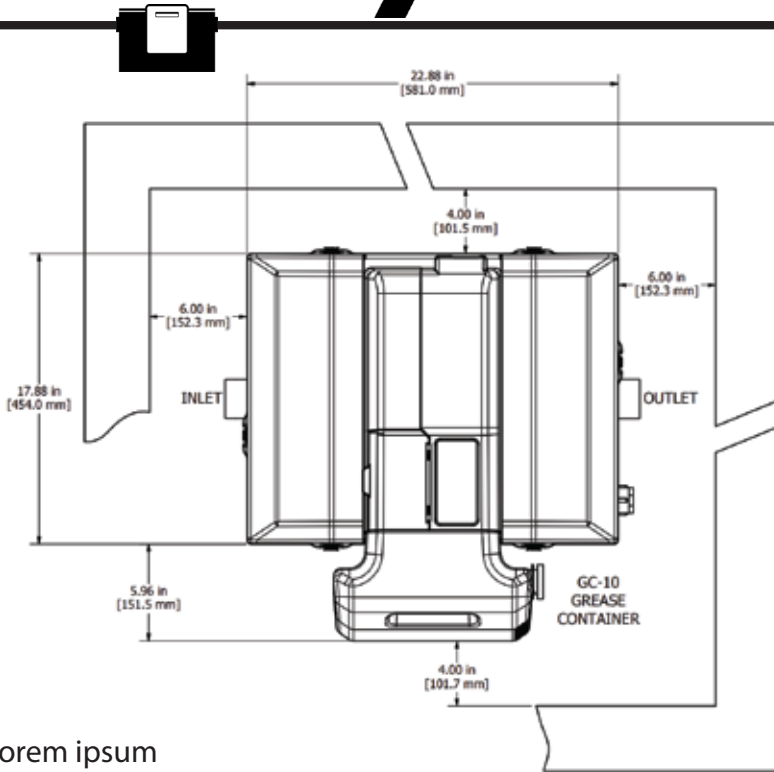

Lorem ipsum

## INSTALLATION NOTES

1. READ instruction manual included with system before installing/operating.
2. Install unit allowing for the minimum clearances shown. Make sure there is sufficient space above Internal Strainer access cover to remove the strainer [minimum of 11.4" (290mm)]
3. Make piping connections with rubber "No Hub" connectors.
4. Keep outlet piping as straight as possible. Use only "sweep" connections.
5. Install vent on outlet piping.
6. Fill the tank with water before energizing the power to the motor and heater.
7. Do not install "P" Trap on outlet connection of tank (unit already has internal gas trap).
8. Do not reduce pipe size on outlet piping
9. Do not pressure test unit.

Equipment must be installed in compliance with all applicable laws, regulations and codes, including plumbing codes. Installation should be performed by a qualified plumbing contractor.

## JOB SPECIFICATION

Grease and oils separator(s) shall be Thermaco Big Dipper automatic grease/oil recovery system(s) as manufactured by Thermaco, Inc., Asheboro, North Carolina as noted on plans.

## AUTOMATIC GREASE REMOVAL DEVICE SPECIFICATIONS

Furnish and install \_\_\_ Thermaco Big Dipper Model No. W-250-IS-T, rotationally molded polyethylene tank automatic self-cleaning grease and oil recovery separator(s) for floor mounted or partially recessed installation, rated to ASME A112.14.3 and/or PDI-G 101 standards at 25 gallons per minute (1.6 liters per second) peak flow with 56.4 Pounds (25.6 Kg) of grease capacity and including as an integral part of the unit, 2" (50 mm) inlet/outlet, 1 rotating gear oleophilic/hydrophobic skimming wheel assembly for automatic grease/oil removal, flow control device, self-regulating electric immersion heater with thermostatic control, 1" (25mm) vessel vent, integral gas trap, digital control for programmable operation, field reversible motor assembly and grease/oil sump outlet, quick release stainless steel lid clamps, fully removable polymer lid with magnetic lid tensioners, internal polymer/stainless steel strainer basket for collection of coarse solids, polymer wiper blade unit and a separate gasketed removable grease and oils collection container with carry handle and pouring spout. Electric assembly shall be tested to comply with pertinent sections of the Standards for Safety ANSI/UL 73 and/or ANSI/UL 1004. Electric motor equipped with overload protection. Two (2) no-hub connectors for plumbing connection provided.

## ELECTRICAL VARIATIONS

- W-250-IS-T: 115V 50/60Hz, 1173 Watts (10.2 Amps)
- W-250-IS-T-E: 230V 50/60Hz, 1173 Watts (5.1 Amps)

## SUBMITTAL OPTIONS

- FS-1 Point Source Flat Strainer (3.4 Gallons of additional solids storage capacity)
- ESU-1 External Strainer (1.16 Gallons of additional solids storage capacity)
- HAG-2 Horizontal Air Gap Assembly with 2" connection (comes with 3 flow restrictors for sink drains)
- HAG-BA-1 Solids Strainer Baskets for use with HAG-2 Assembly (Specify Quantity based on Number of Sinks: \_\_\_)
- SFK-1 Support Frame Kit, stainless steel construction
- CF-VENT-1 Carbon Vent Filter for easy installation and odor protection